

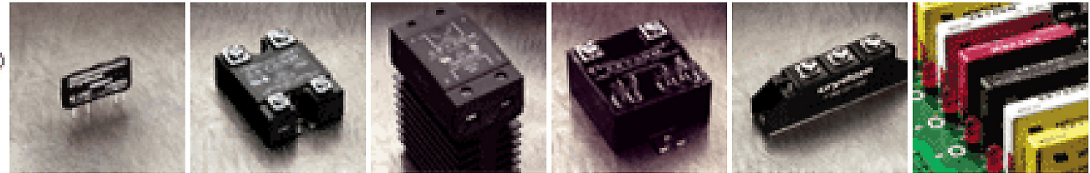

crydom®



[home](#)
 [products](#)
 [sales](#)
 [support](#)
 [contact us](#)
 [about us](#)

Solid State Relays - Panel Mount: D1D/D2D/D4D/D5D



Features

MOSFET output • 7-40Amp •
 100/200/400/500 VDC models • DC
 Switching • DC control • Easily
 paralleled for high current, high voltage
 applications.

Product	INPUT SPECIFICATIONS		OUTPUT SPECIFICATIONS		
	Control Voltage Range	Load Current	Switching Voltage Type	Turn On	Load Voltage Range
D1D07	3.5-32 Volts DC	0.02-7 Amps DC	DC	N/A	0-100 Volts DC
D1D12	3.5-32 Volts DC	0.02-12 Amps DC	DC	N/A	0-100 Volts DC
D1D20	3.5-32 Volts DC	0.02-20 Amps DC	DC	N/A	0-100 Volts DC
D1D40	3.5-32 Volts DC	0.02-40 Amps DC	DC	N/A	0-100 Volts DC
D2D07	3.5-32 Volts DC	0.02-7 Amps DC	DC	N/A	0-200 Volts DC
D2D12	3.5-32 Volts DC	0.02-12 Amps DC	DC	N/A	0-200 Volts DC
D4D07	3.5-32 Volts DC	0.02-7 Amps DC	DC	N/A	0-400 Volts DC

D4D12	3.5-32 Volts DC	0.02-12 Amps DC	DC	N/A	0-400 Volts DC
D5D07	3.5-32 Volts DC	0.02-7 Amps DC	DC	N/A	0-500 Volts DC
D5D10	3.5-32 Volts DC	0.02-10 Amps DC	DC	N/A	0-500 Volts DC
D2D40	3.5-32 Volts DC	0.02-40 Amps DC	DC	N/A	0-200 Volts DC

- MOSFET Output
- Low On-State Resistance
- Paralleling Capability for Higher Currents
- Panel Mount

DC output relays feature MOSFET technology for low on-state resistance, assuring easy paralleling and switching capabilities to 40 amps at up to 200 Vdc. Lower current models are also available to 500 Vdc. All models come in Crydom's standard panel-mount package. Manufactured in Crydom's ISO 9001 Certified facility for optimum product performance and reliability.

OUTPUT SPECIFICATIONS ①

MODEL NUMBERS	D1D07	D1D12	D1D20	D1D40	D2D07	D2D12	D2D40	D4D07	D4D12	D5D07	D5D10
Operating Voltage Range [Vdc]	0-100	0-100	0-100	0-100	0-200	0-200	0-200	0-400	0-400	0-500	0-500
Load Current Range ③ [A dc]	0-7	0-12	0-20	0-40	0-7	0-12	0-40	0-7	0-12	0-7	0-10
Max. Surge Current, [A dc] (10Msec)	15	28	42	106	22	27	106	17	36	19	29
Max. On-State Voltage Drop @ Rated Current [Vdc]	2.0	1.6	2.1	2.1	2.0	2.8	2.1	4.2	4.2	5.7	5.5
Thermal Resistance Junction to Case R_{qJC} [°C/W]	2.2	1.34	1.06	0.83	1.5	1.06	0.83	1.06	0.8	1.0	0.8
Max On-state Resistance @ Rated Current (R_{DS-ON}) [Ohms]	.29	.13	.10	.05	.29	.23	.05	.6	.35	.8	.55
Max. Off-State Leakage Current @ Rated Voltage [mA]	0.1	0.2	0.3	0.3	0.1	0.3	0.3	0.3	0.3	0.2	0.3
Max. Turn-On Time [µsec]	100	100	100	100	100	100	100	100	100	100	100
Max. Turn-Off Time [msec]	1.0	1.0	1.0	1.0	1.0	1.0	1.0	1.0	1.0	1.0	1.0

INPUT SPECIFICATIONS ①

	DC CONTROL
Control Voltage Range	3.5-32 Vdc
Maximum Turn-On Voltage	3.5 Vdc
Minimum Turn-Off Voltage	1.0 Vdc
Nominal Input Impedance	See Note 4
Maximum Input Current	1.6 mA (5 Vdc), 28 mA (32 Vdc) ④

GENERAL NOTES

- ① All parameters at 25°C unless otherwise specified.
- ② Dielectric strength and insulation resistance are measured between input and output.
- ③ Heat sinking required, for derating curves see page 3.
- ④ Input circuitry incorporates active current limiter.

© 2008 CRYDOM Inc., Specifications subject to change without notice.

GENERAL SPECIFICATIONS

Dielectric Strength 60Hz	2500 Vrms
Insulation Resistance (Min.) @ 500 Vdc	10 ⁹ Ohm
Max. Capacitance Input/Output	50 pF
Ambient Operating Temperature Range	-20 to 80°C
Ambient Storage Temperature Range	-20 to 125°C

MECHANICAL SPECIFICATIONS

Weight: (typical)	3.0 oz. (86.5g)
Encapsulation:	Thermally Conductive Epoxy
Terminals:	Screws and Saddle Clamps Furnished, Unmounted

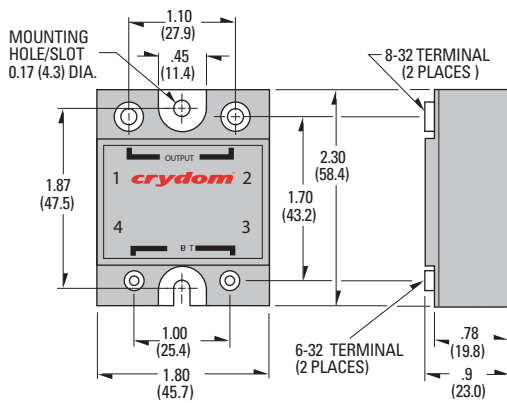

All dimensions are in inches (millimeters)

Screw Torque Requirements: 6-32 Screws - 10 in. lbs. (1.1Nm), 8-32 and 10-32 Screws - 20in. lbs. (2.2Nm) (Screws dry without grease.)

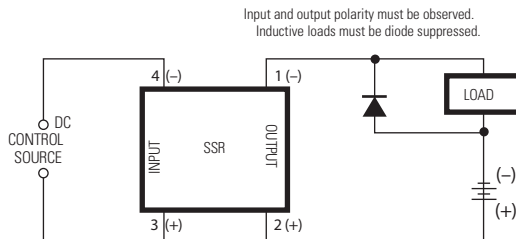

Transient Protection

All loads are inductive, even ones that are not so labeled. An inductive load will produce harmful transient voltages when it is turned off. The more perfect the switch, the larger the transient voltages; the MOSFET output is so nearly an ideal switch that the transient voltages produced by seemingly "non-inductive" loads can cause damage if not suppressed. Diodes should be fast recovery type with PIV rated greater than supply voltage.

MAXIMUM SURGE vs. DURATION

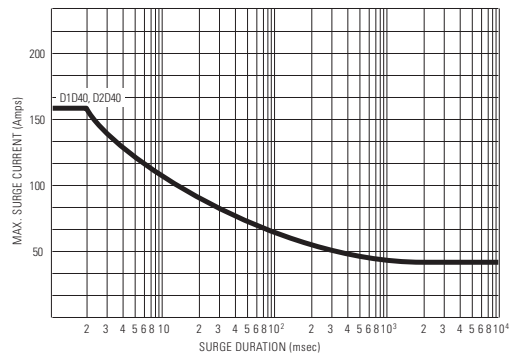
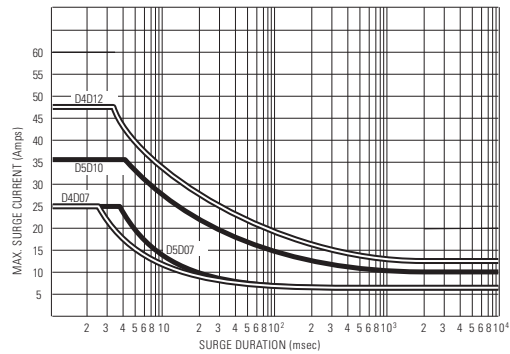
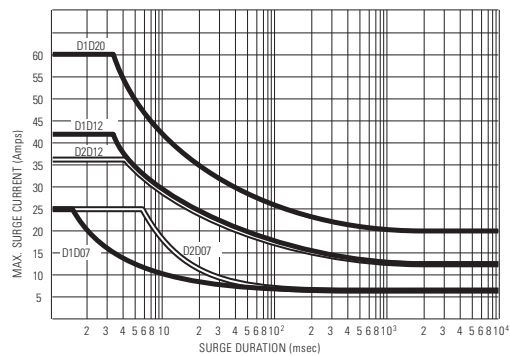

© 2008 CRYDOM Inc., Specifications subject to change without notice.

APPROVALS

UL E116950 (100 Volt Models Only)

